

# Device-to-Device (D2D) Communication for Public Safety in LTE

Release 12 of the 3GPP LTE standard introduced a device-to-device (D2D) interface aimed primarily at allowing LTE to support public safety communication systems.

A key driver for this LTE feature is *FirstNet*, established by the US government. This organization is tasked with creating and maintaining a single high-speed, US nationwide wireless broadband network, dedicated to public safety. Furthermore, it was decided that this *network* would be based on LTE technology. As a result of this decision, a number of US organizations engaged with 3GPP and its members with a view to extend the LTE standard to support features required for *public safety*, for example, communication within out of coverage scenarios.

The first results of this work are standardized as the Proximity Services (ProSe) features in LTE Release 12. This work continues to evolve in Release 13 and beyond. There is now worldwide backing, from the likes of TCCA (TETRA and Critical Communications Association), for the use of LTE in next-generation critical communication systems as a replacement for TETRA and P25.

ProSe introduced sidelink, a new interface with a set of transport and physical channels with associated physical signal, along with the notion of resource pools, which define physical resources in time and frequency that carry D2D control and traffic data. These resource pools, a new concept in the LTE standard, are key to understanding how ProSe traffic can coexist with legacy LTE traffic.

In this application note, we discuss some of the main features of D2D in LTE Release 12 and focus on the concept of resource pools and sidelink. We model and analyze ProSe performance with *LTE System Toolbox™* and explore different options to specify resource pools.

## Direct Discovery vs. Direct Communication

D2D communication offers a number of advantages over network-based communication, including: shorter latency, decreased network traffic, power savings, and a fallback system (in the case of network failure).

Two features are specified as part of ProSe in R12:

- Direct discovery, which is used in commercial applications such as targeted advertising. Direct discovery enables UEs to advertise and discover content of interest in their immediate surroundings (up to a few hundred meters), or transfer data between LTE-enabled devices.
- Direct communication, which is currently reserved for public safety use.

This application note focuses exclusively on direct communication as defined for public safety usage.

Several scenarios are defined for coverage (Figure 1):

- UE in coverage
- UE in partial coverage
- UE out of coverage

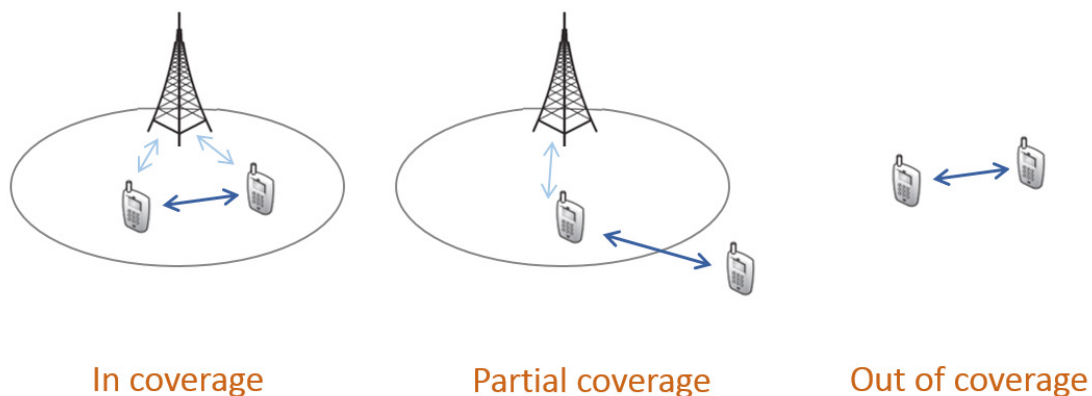

Figure 1: Coverage scenarios.

When at least one of the UEs is in coverage (“in coverage” or “partial coverage” scenario), the LTE network may play a part in coordinating transmission between nearby UEs. On the other hand, one new aspect of direct communication is the ability to have LTE devices communicate without the assistance of the network, as in the “out of coverage” case.

## Sidelink

One of the first decisions the LTE standards body had to make was whether to reuse some of the same physical resources as the downlink or uplink. It was decided that the UE shall transmit on uplink LTE frequencies, using SC-FDMA modulation and resources from the uplink. To explain how the eNodeB or UE selects those uplink resources, however, we first need to introduce sidelink channels and resource pools.

Release 12 of the LTE standard defines sidelink as a new interface with a set of transport and physical channels, with associated physical signals to support deployment of the D2D direct communication and direct discovery features.

The following sidelink physical channels are defined:

- **Physical Sidelink Shared Channel (PSSCH):** This channel carries sidelink data. Sidelink transmission is defined as a one-to-many scheme, meaning that the data is to be received by multiple UEs that belong to a group.
- **Physical Sidelink Control Channel (PSCCH):** This channel is analogous to the PDCCH in that it carries the sidelink control information (SCI) message, which contains information about the resource allocation of the physical sidelink shared channel.
- **Physical Sidelink Discovery Channel (PSDCH):** This channel is not addressed in this application note, as it relates to direct discovery services, not direct communication.
- **Physical Sidelink Broadcast Channel (PSBCH):** This channel carries the frame number, bandwidth, and TDD UL/DL configuration.

The following sidelink physical signals are also defined:

- Demodulation reference signals: These symbols are used for channel estimation.
- Sidelink synchronization signals: primary and secondary synchronization signals (PSSS and SSSS). These synchronization signals are needed to synchronize UEs that are out of coverage and therefore cannot use the primary and secondary synchronization signals emitted by the eNodeB.

The PSBCH occurs at the same time as the PSSS/SSSS, and all three signals are only used when the UE cannot use the primary and secondary synchronization signals emitted by the eNodeB.

### Resource Pools

A resource pool is a set of resources defined by a subset of subframes and resource blocks available within these subframes. The block of resources is repeated with a period, the PSCCH period, which can range from 40 ms to 320 ms. A resource pool is designed to set aside physical resources for transmission of sidelink data (including associated control).

3GPP TS 36.213 section 14.2.3 defines the resource pool in more detail:

- Subframe pools: the set of subframes available for sidelink operation is defined by a bitmap (a 1 indicates a subframe that is available).
- Resource block pools: the set of physical resource blocks (PRB) available is defined by a set of three parameters, **prb-Num**, **prb-Start**, and **prb-End**. These parameters define the start, end and number of resource blocks available, as shown in Figure 2.

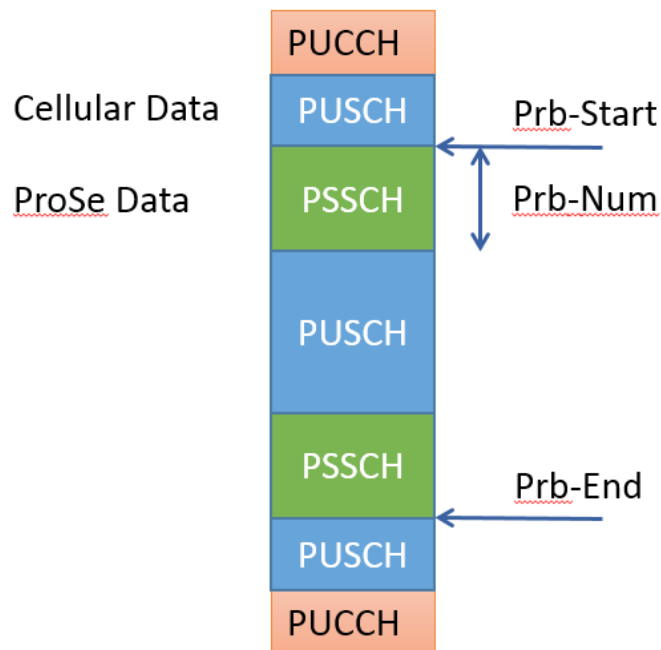

Figure 2: Resource block pool in a subframe that is part of the subframe pool.

These values, along with the PSCCH period, are broadcast in a System Information Block (SIB18). UEs not in coverage use preconfigured values instead, which are defined either on the sim card or in the phone itself.

The following code illustrates the PSCCH period with default values taken from 3GPP TS 36.101 Annex A.7.2 Table 7.2.1-1 for 5MHz bandwidth: 25 resource blocks: “ProSe Direct Communication pre-configuration for E-UTRAN FDD for out-of-network coverage operation (Configuration #1-FDD).” These configurations are defined in the standard to perform demodulation test.

PSCCH Period	40 subframes
prb_Num	13
prb_Start	0
prb_End	24

The values above are identical for the PSSCH and PSCCH. Keep in mind that resource blocks are indexed starting with 0 in the standard. All pictures below, however, index starting with 1, to visually identify resource blocks themselves.

LTE System Toolbox lets users model and visualize this setting with just three lines of code:

```
params = PSCCHPeriod.defaultConfig(1,'5MHz');
period = PSCCHPeriod(params);
period.displayPeriod;
```

Figure 3 shows a PSCCH period for the default 5MHz setting.

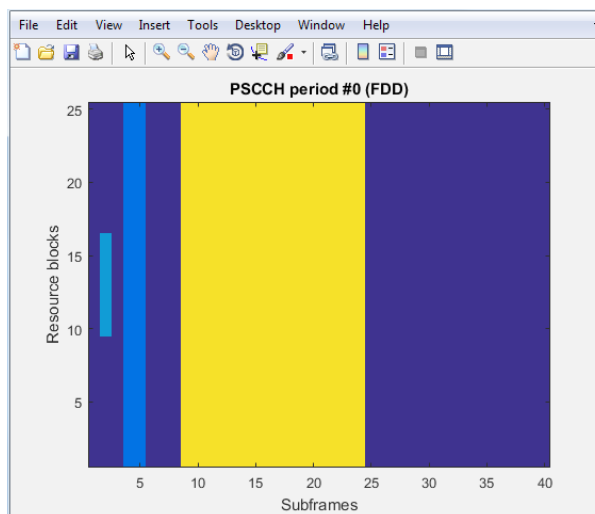

Figure 3: Example of full-band resource pool: synchronization transmission (light blue), control resource pool (dark blue), and shared resource pool (yellow). Resource blocks are numbered from 1 to 25, corresponding to indices 0 through 24.

Here, the resource pool extends across the whole bandwidth, because the start index is 0, the end index is 24, and the one-sided allocation (prb\_Num) is greater than half the bandwidth.

Easily explore a different setting with LTE System Toolbox. The example below illustrates how to change resource allocation values for both the PSCCH and PSSCH.

PSCCH Period	40 subframes
prb_Num	5
prb_Start	3
prb_End	21

```

params = PSCCHPeriod.defaultConfig(1,'5MHz');
params.sc_TF_ResourceConfig_r12.prb_Start_r12 = 3;
params.sc_TF_ResourceConfig_r12.prb_End_r12 = 21;
params.sc_TF_ResourceConfig_r12.prb_Num_r12 = 5;

params.ue_SelectedResourceConfig_r12.data_TF_ResourceConfig_r12.
prb_Start_r12 = 3;
params.ue_SelectedResourceConfig_r12.data_TF_ResourceConfig_r12.
prb_End_r12 = 21;
params.ue_SelectedResourceConfig_r12.data_TF_ResourceConfig_r12.
prb_Num_r12 = 5;
period = PSCCHPeriod(params);
period.displayPeriod;

```

Figure 4 shows the new corresponding pool.

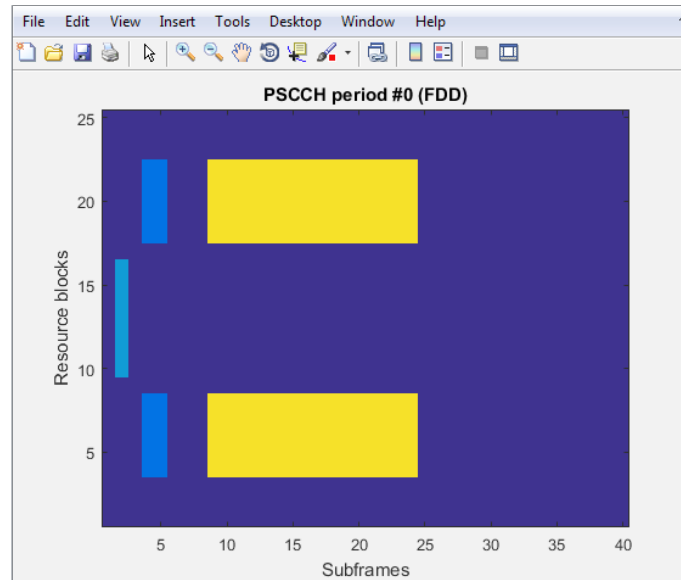

Figure 4: Example of partial-band resource pool.

Here, the resource pool includes two non-overlapping halves, as shown in Figure 2. The first half starts at resource block index 3 ( $prb\_Start$ ), which is the fourth block, and includes five resource blocks ( $prb\_Num$ ). The other half extends to resource block index 21 ( $prb\_End$ ) and also includes five resource blocks ( $prb\_Num$ ).

## Transmission and Modulation

Both PSCCH and PSSCH use resources selected from the resource pools.

The PSCCH is transmitted using QPSK modulation and a very low coding rate. It is sent twice in two different subframes in order to further increase the SNR and, thereby, the probability of correct demodulation.

The PSSCH is transmitted using either QPSK or 16-QAM, and one of the allowed coding rates. This modulation and coding scheme (MCS) is included in the sidelink control information carried by the PSCCH.

Each transport block is sent four times with a fixed redundancy version sequence, in order to let the receiver(s) use soft combining. Note that PSSCH carries data meant to be received by a group of UEs, as opposed to a single UE. Therefore, a closed-loop HARQ scheme cannot be used. Rather, all transmissions are always repeated four times, although any individual UE may successfully decode a transport block in fewer than four transmissions.

The PSCCH and PSSCH are mapped to physical resources included in the resource pools described earlier, using one of two strategies. LTE Release 12 defines two transmission modes:

- Transmission mode 1 (network-directed): When the UE is in coverage, the eNodeB can dynamically assign resources to the UE for D2D transmission. In this transmission mode, the eNodeB can guarantee no collision between any sidelink transmission and any uplink transmission, or between sidelink transmissions.
- Transmission mode 2 (UE-selected): The UE selects which resources to use for transmission. Transmission mode 2 is applicable to all scenarios, in coverage and out of coverage. The resources are selected at random to minimize the collision risk.

## Sidelink Performance

We now want to illustrate a concrete example of a resource pool configuration and how to determine the performance of sidelink control and data channels using LTE System Toolbox. LTE System Toolbox offers all necessary channels and physical signals such as sidelink control, broadcast and shared channels, along with synchronization and demodulation reference signals.

We use LTE System Toolbox to:

- Determine the SNR needed to successfully set up the sidelink channel
- Determine how many retransmissions are needed to decode the PSCCH and PSSCH channels for a given SNR

In this example, we assume transmission mode 2, meaning that the transmitting UE must randomly select suitable resources from a predefined resource pool. Note that the UE could be in coverage or out of coverage.

The main steps in the example are:

- Set up a resource pool according to predefined parameters (\*).
- Create a Sidelink Control Information (SCI) message. This message carries all necessary pieces of information including resource allocation for the PSSCH (via a Resource Indicator Value or RIV), and modulation and coding scheme.
- Create a PSSCH transport block.
- Transmit the SCFDMA modulated signal over a channel.
- Demodulate the signal.
- Blindly detect the SCI by trying out all possible PSCCH resources.
- Once the SCI is decoded, extract the relevant resource blocks where PSSCH is located.
- Decode the PSSCH over up to four retransmissions (open-loop HARQ).

The simulation determines the error rate on PSCCH and PSSCH decoding. Here, we chose an MCS value of 11, which corresponds to 16-QAM.



```

while (p<=nPeriods)

    % Update PSCCH period number
    period.Config.NPSCCHPeriod = p - 1;

    % Choose a random PSCCH resource
    sciMessage.PSCCHResource = randi([0 period.NumPSCCHResource-1]);

    % Choose a random PSSCH resource
    sciMessage.Allocation.RIV = RIVs(randi(length(RIVs)));

    % Generate PSCCH period waveform
    txWaveform = period.generateWaveform(sciMessage);

    [...]

```

The code excerpt above shows the main loop where a random resource is chosen for the PSCCH. A random allocation is chosen for the PSSCH, as encoded by the RIV. The sidelink signal is generated with a single call to the `generateWaveform` method.

Figure 5 shows which resources were actually picked by the UE for a particular subframe for PSCCH and PSSCH. They are highlighted in green.

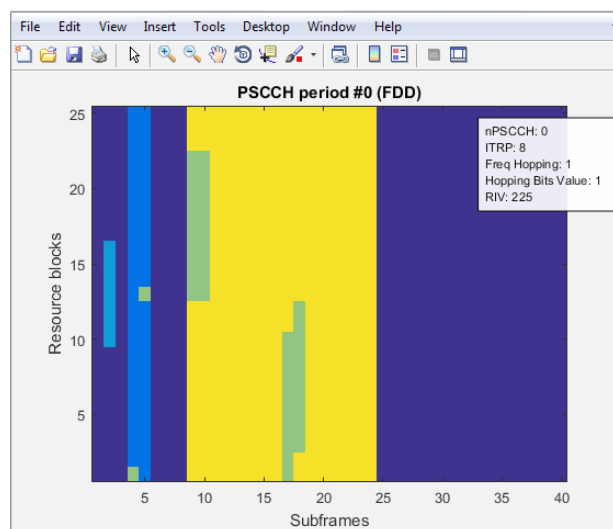

Figure 5: Example of PSCCH and PSSCH allocation within a resource pool. Resource blocks are indexes starting with 1.

Observe the two PSCCH and four PSSCH transmissions in different subframes that belong to their respective resource pools. The PSCCH transmissions occupy one physical resource block each (1 and 13) in the first and second subframes of the PSCCH resource pool (dark blue). PSSCH transmission occupies contiguous physical resource blocks in two groups of two consecutive subframes within the (yellow) PSSCH resource pool: PRBs 13 through 22, 13 through 22, 1 through 10, and 3 through 12.

Finally, the BLER for both PSCCH and PSSCH are shown as a function of the SNR (Figure 6), as well as the number of retransmissions that were combined (Figure 7). Combining stops when the channel is successfully decoded or the maximum number of transmissions is reached (2 for PSCCH, 4 for PSSCH).

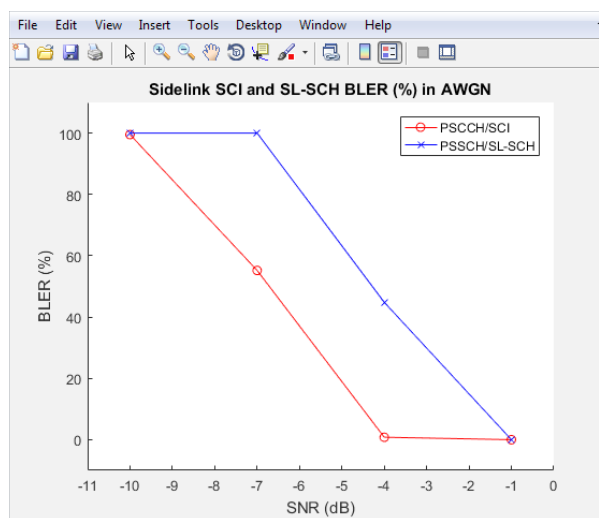

Figure 6: BLER for sidelink SCI and SL-SCH over 1000 periods.

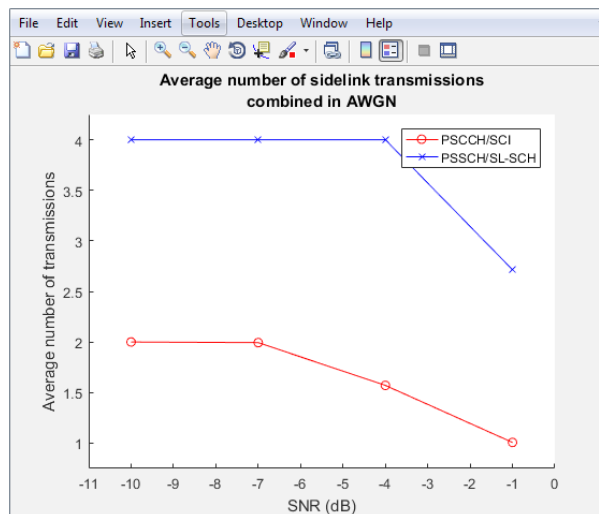

Figure 7: Average number of transmissions combined for sidelink SCI and SL-SCH over 1000 periods.

For low SNRs, the receiver always needs both PSCCH and all four PSSCH transmissions.

For -10dB, we can see that the BLER is 100%, which means that even with all retransmissions, the receiver is not able to correctly decode either channel with this weak signal. Conversely, at -1dB, the BLER is always 0, meaning that both the SCI and SL-SCH are correctly decoded, after an average of 1 and 2.7 transmissions respectively.

## Conclusion

The LTE standard is constantly evolving and introducing new capabilities supported by new features. Proximity services are one of the main recent additions to the LTE standard, with applications in both public safety and commercial deployments. Furthermore, LTE Release 14 may add a Vehicle-to-Vehicle and Vehicle-to-Everything capability (V2V/V2X) based on the sidelink with suitable modifications, to accommodate specific requirements such as low latency and high reliability.

LTE System Toolbox provides the ability to keep up with new standard development, generate standard-compliant signals, and analyze the performance of new scenarios.

In particular, LTE System Toolbox provides the ability to investigate the performance of direct communication scenarios under various configurations.

## References

The main lower stack 3GPP standard specification references are:

1. TS 36.211 V12.7.0 Section 9 – Sidelink
2. TS 36.212 V12.6.0 Section 5.4 – Sidelink transport channels and control information
3. TS 36.213 V12.7.0 Section 14 – UE procedures related to Sidelink
4. TS 36.331 V12.7.0 Section 5.10, Section 6.3.8, and others
5. TS 36.101 V13.2.1 Annex A.6 – Sidelink reference measurement channels

(\*) TS 36.101 Table 12.2.1-1 (Sidelink UE 2, reference measurement channel CC.3 FDD for the control channel, CD.1 FDD for the shared channel) and Annex A.7.2.1-1 (Configuration #1-FDD)

## Products Used

*MATLAB*

*LTE System Toolbox*

## Learn More

**Wireless Communications Design with MATLAB**

[mathworks.com/solutions/wireless-communications](http://mathworks.com/solutions/wireless-communications)